

## KNOCKOUT DOUBLE DIAMETER UP

TOOL CODE K4

ORDERING SPECIFICATIONS

STANDARD TAB DIMENSIONS		
MATERIAL THICKNESS	"C"	"D"
.020 - .045(0.51 - 1.14)	.060(1.52)	.030(0.76)
.046 - .070(1.16 - 1.78)	.090(2.29)	.050(1.27)
.071 - .097(1.80 - 2.46)	.120(3.05)	.060(1.52)
.098 - .127(2.49 - 3.23)	.180(4.57)	.090(2.29)
.128 - .179(3.25 - 4.55)	.250(6.35)	.125(3.18)

STANDARD TAB LOCATIONS		
"A" Ø or "B" Ø	LOCATION	
	LOWER	UPPER
0 - 1.374 (0.00 - 34.90)		
1.375 - MAXIMUM (34.93 - MAXIMUM)		

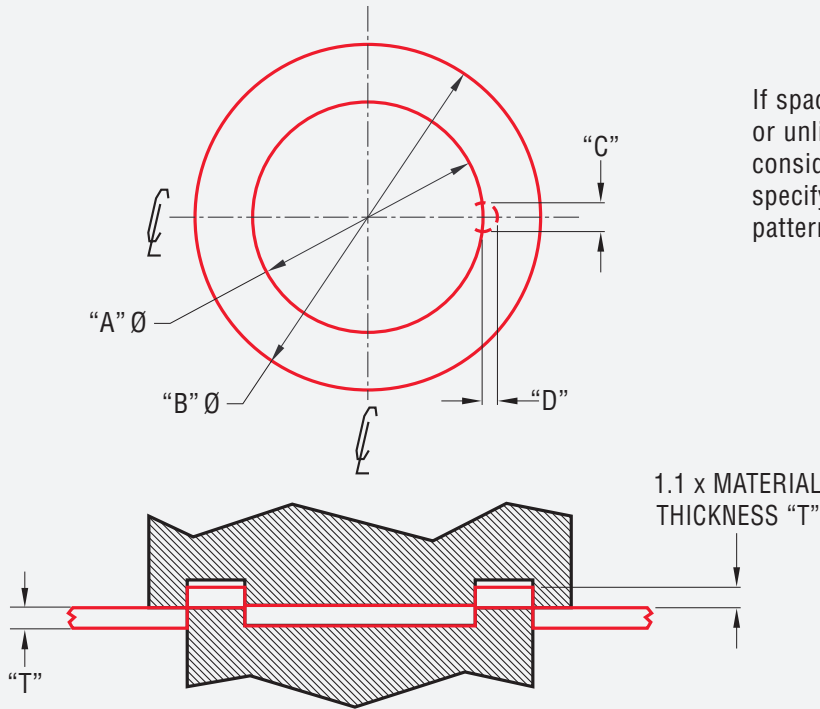

If spacing between like or unlike forms is a consideration, please specify or submit a full pattern drawing.

### TOOL INFORMATION

Select "A" Ø and "B" Ø from standard table. Fill in "C" and "D" only if not MATE standard.

A Ø \_\_\_\_\_  
 B Ø \_\_\_\_\_  
 C \_\_\_\_\_  
 D \_\_\_\_\_

### GENERAL INFORMATION

Material Type \_\_\_\_\_  
 Material Thickness "T" \_\_\_\_\_  
 Machine Type \_\_\_\_\_  
 Tooling Style \_\_\_\_\_  
 Tooling Station \_\_\_\_\_  
 Dimensions filled in by \_\_\_\_\_  
 Approved By \_\_\_\_\_

Ø indicates DIAMETER



Dimensions in inches (millimeters)